

Single skin packaged roof top units with digital scroll compressors and EC inverter plug-fans



VERSIONS

RT-AS/T/EC/H

RT-AS/T/EC/H/MIX

RT-AS/T/EC/H/ECO

Reversible heat pump

Reversible heat pump with 2-damper Free cooling

Reversible heat pump with 3-damper Free cooling

TECHNICAL FEATURES

- Compressors. DIGITAL Scroll and ON/OFF Scroll with oil level sight glass. They are fitted with internal overheat protection and crankcase heater, installed on rubber shock absorbers.
- Microprocessor. For automatic control of the unit.
- Electronic proportional device. Attenuates the sound level of the unit using a stepless regulation of fan rotation speed, the device also allows the operation of up to outside air temperatures to -20°C.
- Control logic of the DIGITAL Scroll compressor. Adjusts with pulse modulation the power delivered by the compressor as a function of the thermal load of the system, the condensing pressure and temperature of the outside air.
- Condenser. Made up of a finned coil with copper pipes and aluminium fins.
- Evaporator. Made up of a finned coil with copper pipes and aluminium fins.
- Condensing section fans. Axial fans directly coupled to a three-phase electric motor with external rotor. A safety fan guard is fitted on the air flow discharge. Condensing control till -20°C included.
- Air treatment and intake air section fans. EC Inverter Plug-Fans delivery fans with high energy efficient reverse blades with external rotor motor and electronic speed. EC Inverter Plug-Fans intake fans with high energy efficient reverse blades with external rotor motor and electronic speed (ECO versions only).
- Basic version air treatment section. It includes: reverse blade delivery EC Inverter Plug-Fans; folded cell flat filters bench with G4 efficiency and heat exchange coil, with copper pipes and aluminium fin, positioned on a relevant stainless steel condensate drip tray. The delivery flow and intake panels can be easily removed and allow to choose the most suitable configuration for installation needs.
- MIX version air treatment section. In addition to the components installed on the basic version, it includes: two aluminium dampers with wing-shaped section, motorised by servomotors with spring return. The opposite movement is guaranteed by nylon gear transmissions.
- ECO version air treatment section. In addition to the components installed on the basic version, it includes: reverse blade intake EC Inverter Plug-Fans and aluminium dampers with wing-shaped section, motorised (the shutters have opposite movement). Expulsion, circulation and fresh air are managed by the microprocessor on the base unit. Depending on the temperature of the circulation and external air this microprocessor modulates shutter opening and manages power partialisations of the cooling circuit to guarantee the good condition of the conditioned air. The ECO version adjustments are managed automatically in Free-Cooling and Free-Heating mode.

RT-AS/T/EC/H

0264 0273 0284 0295

RT-AS/T/EC/H

(1) Pot. frigorifera / Cooling capacity / Puis. refroidis	kW	64,9	73,8	85,6	96,8	Kälteleistung / P.frigorifica / Capacitate de racire (1)
(1) (3) Pot. assorbita / Absorbed power / Puis. absorbée	kW	20,9	24,2	27,2	30,0	Leistungsaufnahme / Pot. absorbida / Putere absorbita (1) (3)
(2) Pot. termica / Heating capacity / Puis. chauffage	kW	62,9	71,1	81,2	92,9	Wärmeleistung / Pot. calorifica / Capacitate de incalzire (2)
(2) (3) Pot. assorbita / Absorbed power / Puis. absorbée	kW	18,6	21,7	25,2	28,1	Leistungsaufnahme / Pot. absorbida / Putere absorbita (2) (3)
Sezione trattamento aria / Air treatment section / Section traitement air						Verflüssigungsektion / Sección tratamiento aire / Sec. detratare a aerului
Portata aria / Air flow / Débit d'air	m³/s	2,50	2,78	3,34	3,61	Nennluftmenge / Caudal de aire / Debit aer
Prevalenza utile / Ext. pressure / Pression utile (*)	Pa	200				Ext. Pressung / Prevalència útil / Presiune utila pompa / (*)
Ventilatori / Fans / Ventilateurs	n°	1 EC Inverter Plug Fan				Ventilatoren / Ventiladores / Ventilatoare
Filtri / Filters / Filtre	-	G4				Filter / Filtros / Filtre
Sezione ripresa aria / Air intake section / Section reprise air						Luftansaug Sektion / Sección de entrada aire / Sectiune aspiratie aer
Portata aria / Air flow / Débit d'air	m³/s	2,00	2,22	2,67	2,89	Nennluftmenge / Caudal de aire / Debit aer
Prevalenza utile / Ext. pressure / Pression utile (*)	Pa	100				Ext. Pressung / Prevalència útil / Presiune utila pompa / (*)
Ventilatori / Fans / Ventilateurs	n°	1 EC Inverter Plug Fan				Ventilatoren / Ventiladores / Ventilatoare
Sezione motocondensante / Condensing section / Section condensant						Luftbehandlungsektion / Sección trato aire / Sectiune condensare
Compressori / Compressors / Compresseurs	n°	1 Digital Scroll + 1 On-Off				Verdichter / Compresores / Compressoare
Circ. frigoriferi / Refrigerant circuits / Circ. frigorifique	n°	1				Kältekreislauf / Circ. frigorificos / Circuite frigorifice
Gradini di parzializz. / Capacity steps / Degrés de découpage	n°	Stepless				Drosselungsstufen / Grados de parzializz. / Grade de partializare
Ventilatori / Fans / Ventilateurs	n°	1	1	2	2	Ventilatoren / Ventiladores / Ventilatoare
Assorbimenti totali / Total electrical consumption						Absorptions totales / Consumos totales
Alimentazione / Power supply / Alimentation	V/Ph/Hz	400/3/50				Elektrische Einspeisung / Alimentación / Alimentare
Corr. max funz. / Max Running current / Cour. refr.	A	53	56	65	69	Strom Kühlfunktion / Corr. max función / Curent max in funct
Corr. max spunto / Max inrush current / Cour. cha.	A	190	165	188	201	Strom Heizfunktion / Corr.máx. arranque / Curent max la pornire
(4) Pressione sonora / Sound pressure / Pres. sonore	dB(A)	56	56	60	60	Schalldruckpegel / Rumorosidade / Nivel de zgomot (4)
Batteria ad acqua calda / Hot water coil / Batterie eau chaude						Warmwasser Wärmetauscher / Batería agua caliente / Baterie apa calda
(5) Resa termica / Heating capacity / Rendement thermique	kW	65,4	68,6	74,9	78,9	Wärmeleistung / Eficiencia térmica / Cap. incalzire (5)
Portata acqua / Water flow / Débit d'eau	l/s	1,56	1,64	1,79	1,89	Kaltwassermenge / Caudal de agua / Debit de apa
Batteria elettrica / Electric heating / Batterie électrique						Elektrischer Wärmetauscher / Batería eléctrica / Debit de apa
Pot. termica / Heating capacity / Puis. chauffage	kW	21	27	27	27	Wärmeleistung / Pot. calorifica / Capacitate de incalzire
Corr. max funz. / Max Running current / Cour. refr.	A	30	39	39	39	Strom Kühlfunktion / Corr. max función / Curent max in funct.
Peso di trasporto / Transport weight / Poids de transport						Transportgewicht / Peso de transporte / Greutate transport
STD	kg	1280	1315	1370	1380	STD
MIX	kg	1320	1350	1395	1415	MIX
ECO	kg	1325	1360	1405	1420	EC

RT-AS/T/EC/H

02109 03126 03145 03169

RT-AS/T/EC/H

(1) Pot. frigorifera / Cooling capacity / Puis. refroidis	kW	111	128	147	171	Kälteleistung / P.frigorifica / Capacitate de racire (1)
(1) (3) Pot. assorbita / Absorbed power / Puis. absorbée	kW	35,4	41,1	45,9	54,1	Leistungsaufnahme / Pot. absorbida / Putere absorbita (1) (3)
(2) Pot. termica / Heating capacity / Puis. chauffage	kW	107	123	142	162	Wärmeleistung / Pot. calorifica / Capacitate de incalzire (2)
(2) (3) Pot. assorbita / Absorbed power / Puis. absorbée	kW	31,0	38,1	42,6	50,1	Leistungsaufnahme / Pot. absorbida / Putere absorbita (2) (3)
Sezione trattamento aria / Air treatment section / Section traitement air						Verflüssigungsektion / Sección tratamiento aire / Sec. detratare a aerului
Portata aria / Air flow / Débit d'air	m³/s	4,44	4,44	5,83	6,67	Nennluftmenge / Caudal de aire / Debit aer
Prevalenza utile / Ext. pressure / Pression utile (*)	Pa	200				Ext. Pressung / Prevalència útil / Presiune utila pompa / (*)
Ventilatori / Fans / Ventilateurs	n°	1 EC Inverter Plug Fan		2 EC Inverter Plug Fan		Ventilatoren / Ventiladores / Ventilatoare
Filtri / Filters / Filtre	-	G4				Filter / Filtros / Filtre
Sezione ripresa aria / Air intake section / Section reprise air						Luftansaug Sektion / Sección de entrada aire / Sectiune aspiratie aer
Portata aria / Air flow / Débit d'air	m³/s	3,55	3,55	4,72	5,33	Nennluftmenge / Caudal de aire / Debit aer
Prevalenza utile / Ext. pressure / Pression utile (*)	Pa	100				Ext. Pressung / Prevalència útil / Presiune utila pompa / (*)
Ventilatori / Fans / Ventilateurs	n°	1 EC Inverter Plug Fan				Ventilatoren / Ventiladores / Ventilatoare
Sezione motocondensante / Condensing section / Section condensant						Luftbehandlungsektion / Sección trato aire / Sectiune condensare
Compressori / Compressors / Compresseurs	n°	1 Digital+1 On-Off	1 Digital Scroll + 2 On-Off			Verdichter / Compresores / Compressoare
Circ. frigoriferi / Refrigerant circuits / Circ. frigorifique	n°	1				Kältekreislauf / Circ. frigorificos / Circuite frigorifice
Gradini di parzializz. / Capacity steps / Degrés de découpage	n°	Stepless				Drosselungsstufen / Grados de parcializz. / Grade de partializare
Ventilatori / Fans / Ventilateurs	n°	2	2	2	3	Ventilatoren / Ventiladores / Ventilatoare
Assorbimenti totali / Total electrical consumption						Absorptions totales / Consumos totales
Alimentazione / Power supply / Alimentation	V/Ph/Hz	400 / 3 / 50				Elektrische Einspeisung / Alimentación / Alimentare
Corr. max funz. / Max Running current / Cour. refr.	A	79	91	110	131	Strom Kühlfunktion / Corr. max función / Curent max in funct
Corr. max spunto / Max inrush current / Cour. cha.	A	208	215	242	260	Strom Heizfunktion / Corr.máx. arranque / Curent max la pornire
(4) Pressione sonora / Sound pressure / Pres. sonore	dB(A)	60	60	61	61	Schalldruckpegel / Rumorosidade / Nivel de zgomot (4)
Batteria ad acqua calda / Hot water coil / Batterie eau chaude						Warmwasser Wärmetauscher / Batería agua caliente / Baterie apa calda
(5) Resa termica / Heating capacity / Rendement thermique	kW	84,9	84,9	103	110	Wärmeleistung / Eficiencia térmica / Cap. incalzire (5)
Portata acqua / Water flow / Débit d'eau	l/s	2,03	2,03	2,46	2,62	Kaltwassermenge / Caudal de agua / Debit de apa
Batteria elettrica / Electric heating / Batterie électrique						Elektrischer Wärmetauscher / Batería eléctrica / Debit de apa
Pot. termica / Heating capacity / Puis. chauffage	kW	40	40	40	48	Wärmeleistung / Pot. calorifica / Capacitate de incalzire
Corr. max funz. / Max Running current / Cour. refr.	A	59	59	59	69	Strom Kühlfunktion / Corr. max función / Curent max in funct.
Peso di trasporto / Transport weight / Poids de transport						Transportgewicht / Peso de transporte / Greutate transport
STD	kg	1475	1570	1920	2020	STD
MIX	kg	1515	1610	1940	2060	MIX
ECO	kg	1520	1615	1945	2065	EC

(1)Temp. aria ingresso evaporatore 27 °C b.s. 19 °C b.u.; aria esterna 35 °C;
 (2)Temp. aria ingresso condensatore 20 °C; aria esterna 7 °C b.s./6 °C b.u.
 (3)Esclusa la potenza assorbita dai ventilatori plug-fan EC inverter.
 (4) Livello medio di pressione sonora rilevato in campo libero ad 1 m dall'unità (Q=2) secondo ISO 3744
 (5)Temperatura aria ingresso 20 °C; temperatura acqua 70 / 60 °C.
 (1)Temp. eau entrée évaporateur 27 °C b.s. 19 °C b.u.; température air 35 °C;
 (2)Temp. air entrée condenseur 20 °C; température air 7 °C b.s./6 °C b.u.
 (3)Exclue la puissance absorbée par les ventilateurs EC inverter plug-fan.
 (4)Niveau de pression sonore relevé dans un champ libre à 1 m de l'unité (Q=2) selon ISO 3744.
 (5)Température air entrée 20 °C; Température eau 70 / 60 °C

(1)Evaporator inlet air temperature 27 °C d.b. 19 °C w.b.; air temperature 35 °C;
 (2)Condensator inlet air temperature 20 °C; air temperature 7 °C d.b./6 °C w.b.
 (3)Excluded the power absorbed by plug-fan EC inverter.
 (4) Sound pressure level measured in free field conditions at 1 m from the unit (Q=2) according to ISO 3744.
 (5)Inlet air temperature 20 °C; water temperature 70 / 60 °C.
 (1)Verdampfer eintritt Wassertemperatur 27 °C t.t. 19 °C f.t.; Umgebungstemp. 35 °C;
 (2)Verflüssiger eintritt Umgebungstemp. 20 °C; Umgebungstemperatur 7 °C t.t./6 °C f.t.
 (3)Leistungsaufnahme der plug-fan EC inverter ausgeschlossen.
 (4)Schalldruckpegel in freiem Feld 1 m von der Einheit (Q=2) gemäß ISO 3744.
 (5)Eintrittstemperatur Luft 20 °C; Wassere temperatur 70 / 60 °C

(1)Temperatura aeriului de intrare in evapo-rator 27 °C b.s. 19 °C b.u.; temperatura exteriora 35 °C;
 (2)Temperatura aeriului de intrare in condensator 20 °C; temperatura exteriora 7 °C b.s./6 °C b.u.
 (3)Exclusa puterea absorbita de ventilatoarele tip Plug-fan EC inverter.
 (4)Temperatura aeriului de intrare 20 °C; temperatura apei de intrare 70 °C; temperatura apei la iesire 60 °C.
 (5) Nivel mediu de zgomot masurat in camp liber la 1 m de unitate si conform ISO 3744.

(1)Temperatura aeriului de intrare in evapo-rator 27 °C b.s. 19 °C b.u.; temperatura exteriora 35 °C;
 (2)Temperatura aeriului de intrare in condensator 20 °C; temperatura exteriora 7 °C b.s./6 °C b.u.
 (3)Exclusa puterea absorbita de ventilatoarele tip Plug-fan EC inverter.
 (4)Temperatura aeriului de intrare 20 °C; temperatura apei de intrare 70 °C; temperatura apei la iesire 60 °C.
 (5) Nivel mediu de zgomot masurat in camp liber la 1 m de unitate si conform ISO 3744.

INDUSTRIAL RANGE

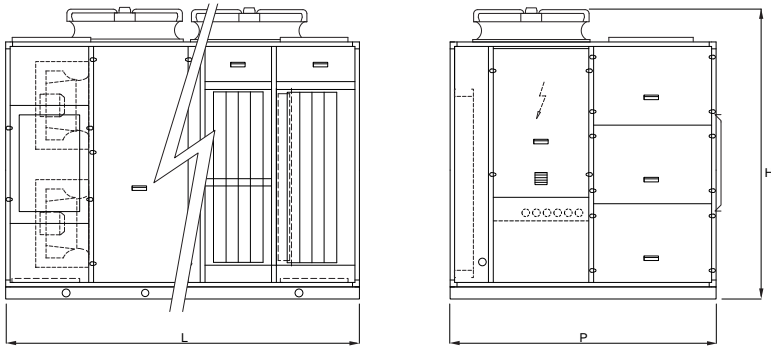

RT-AS/T/EC/H	0264	0273	0284	0295	02109	03126	03145	03169
L mm	STD 2930	2930	2930	2930	2930	2930	3930	3930
P mm	STD 2200	2200	2200	2200	2200	2200	2200	2200
H mm	STD 2125	2125	2125	2125	2125	2125	2125	2125

FACTORY FITTED ACCESSORIES

- IM** Automatic circuit breakers. Alternative to fuses and thermal relais.
- SL** Unit silencement. The compressors are equipped with sound-absorbing covering.
- RFM** Cooling circuit shut-off valve on discharge line.
- RFL** Cooling circuit shut-off valve on liquid line.
- TXC** Condensing coil with pre-coated fins.
- TXE** Evaporating coil with pre-coated fins.
- FTM6** Plate filters efficiency M6.
- FTF7** Plate filters efficiency F7.
- FTF8** Plate filters efficiency F8.
- AT** Constant air flow regulation control. Allows to keep the air flow rate constant by adjusting fan speed, adapting to the plant pressure drops. The system also allows to compensate the progressive dirtying of the filters.
- AT/P** Constant available static pressure regulation control. Allows to keep the available static pressure constant by adjusting fan speed, adapting to the plant pressure drops. The system also allows to compensate the progressive dirtying of the filters.
- WS2** 2-Row hot water coil with 3-Way valve. It can be managed as post-heating or as integration to the capacity of the heat pump.
- EHG** Electrical heater with step regulation. It can be managed as post-heating or as integration to the capacity of the heat pump.
- CH** Enthalpic control (ECO only). Allows to have Free-Cooling managed with enthalpy logic instead of only temperature.
- SQ** Air quality probe. Allows to adjust the introduction of fresh air depending on the quality of the air, reducing waste caused by the conditioning of external air exceeding that effectively requested.
- PF** Filters control differential pressure switch. The device is installed and connected to the electric control board and allows to detect and display that the maximum dirt level of the filters has been reached.
- IS** Modbus RTU protocol, RS485 serial interface.
- ISB** BACnet MSTP protocol, RS485 serial interface.
- ISBT** BACnet TCP/IP protocol, Ethernet port.
- ISL** LonWorks protocol, FFT-10 serial interface.
- CP** Potential free contacts. For remote alarm and control.

LOOSE ACCESSORIES

- MN** High and low pressure analog gauges.
- CS** Dampers rain hood.
- CR** Remote control panel. To be installed in the room for remote control of the unit, with the same functions as that inserted in the machine.
- RP** Coil protection metallic guards. In steel with cataphoresis treatment and painting.
- AG** Rubber shock absorbers. To be inserted at the bottom of the unit to dampen possible vibrations due to the type of floor where the machine is installed.