

Procedures and Technical Points for System Installation



New Refrigerant R410A

2-WAY Multi U-16GE2E5, U-20GE2E5, U-25GE2E5, U-30GE2E5
2-WAY High Power Multi U-16GEP2E5, U-20GEP2E5, U-25GEP2E5
3-WAY Multi U-16GF2E5, U-20GF2E5, U-25GF2E5

CONTENTS

IMPORTANT!..... 1
 Please Read Before Starting

SAFETY PRECAUTIONS.....2

1. SELECTING THE INSTALLATION LOCATION3

2. PRECAUTIONS FOR INSTALLATION WORK10

3. INSTALLATION PROCEDURE13

4. OPENING THE CLOSED VALVES17

5. AFTER INSTALLATION IS COMPLETED...18

6. ENGINE REPLACEMENT PATHWAY18

7. USING A VIBRATION-RESISTANT FRAME18

- Check that all provided parts are present.
 - This manual (“Procedures and Technical Points for System Installation”)
 - “Procedures and Technical Points for Electrical Wiring Work (Outdoors)”
 - “Procedures and Technical Points for Test Run”
 - Label showing the actual length of refrigerant tubing and amount of refrigerant charge
 - Seal labels
 - Remote power switch label
 - Exhaust Drain Hose

- The manuals **Procedures and Technical Points for Electrical Wiring Work (Outdoors)** and **Procedures and Technical Points for Test Run** are also attached for the outdoor unit. Be sure to read this manual in conjunction with these service manuals.

IMPORTANT! Please Read Before Starting

This air conditioning system meets strict safety and operating standard. As the installer or service person, it is an important part of your job to install or service the system so it operates safely and efficiently.

For safe installation and trouble-free operation, you must:

- Carefully read this instruction booklet before beginning.
- Follow each installation or repair step exactly as shown.
- Observe all local, state, and national electrical codes.
- Pay close attention to all warning and caution notices given in this manual.



WARNING

This symbol refers to a hazard or unsafe practice which can result in severe personal injury or death.



CAUTION

This symbol refers to a hazard or unsafe practice which can result in personal injury or product or property damage.

If Necessary, Get Help

These instructions are all you need for most installation sites and maintenance conditions. If you require help for a special problem, contact our sales/service outlet or your certified dealer for additional instructions.

In Case of Improper Installation

The manufacturer shall in no way be responsible for improper installation or maintenance service, including failure to follow the instructions in this document.

SPECIAL PRECAUTIONS

WARNING When Wiring



ELECTRICAL SHOCK CAN CAUSE SEVERE PERSONAL INJURY OR DEATH. ONLY A QUALIFIED, EXPERIENCED ELECTRICIAN SHOULD ATTEMPT TO WIRE THIS SYSTEM.

- Do not supply power to the unit all wiring and tubing are completed or reconnected and checked.
- Highly dangerous electrical voltage are used in this system. Carefully refer to the wiring diagram and these instructions when wiring. Improper connections and inadequate grounding can cause **accidental injury or death**.
- **Ground the unit** following local electrical codes.
- Connect all wiring tightly. Loose wiring may cause overheating at connection points and a possible fire hazard.

When Transporting

Be careful when picking up and moving the indoor and outdoor units. Get a partner to help, and bend your knees when lifting to reduce strain on your back. Sharp edges or thin aluminum fins on the air conditioner can cut your fingers.

When Installing...

...In a Ceiling or Wall

Make sure the ceiling/wall is strong enough to hold the unit's weight. It may be necessary to construct a strong wood or metal frame to provide added support.

...In a Room

Property insulate any tubing run inside a room to prevent "sweating" that can cause dripping and water damage to walls and floors.

...In Moist or Uneven Locations

Use a raised concrete pad or concrete blocks to provide a solid, level foundation for the outdoor unit. This prevents water damage and abnormal vibration.

...In an Area with High Winds

Securely anchor the outdoor unit down with bolts and a metal frame. Provide a suitable air baffle.

...In a Snowy Area (for Heat Pump-type Systems)

Install the outdoor unit on a raised platform that is higher than drifting snow. Provide snow vents.

When Connecting Refrigerant Tubing

- Use the frame method for connecting tubing.
- Apply refrigerant lubricant to the matching surfaces of the flare and union tubes before connecting them, then tighten the nut with a torque wrench for a leak-free connection.
- Check carefully for leaks before starting the test run.

When Servicing

- Turn the power OFF at the main power box (mains) before opening the unit to check or repair electrical parts and wiring.

- Keep your fingers and clothing away from any moving parts.
- Clean up the site after you finish, remembering to check that no metal scraps or bits of wiring have been left inside the unit being serviced.

Gas Supply Pressure

Gas Supply	Pressure(mbar)			Gas Supply	Pressure(mbar)		
	Min.	Normal	Max.		Min.	Normal	Max.
G20, G25 (Natural Gas)	17	20	25	G31 (LPG)	25	37	45

Others



CAUTION

- Ventilate any enclosed areas when installing or testing the refrigeration system. Escaped refrigerant gas, on contact with fire or heat, can produce dangerously toxic gas.
- Confirm upon completing installation that no refrigerant gas is leaking. If escaped gas comes in contact with a stove, gas water heater, electric room heater or other heat source, it can produce dangerously toxic gas.

NOTICE

- The English text is the original instructions. Other languages are translation of the original instructions.

SAFETY PRECAUTIONS



WARNING

- Be sure to arrange installation from the dealer where the system was purchased or using a professional installer. If you attempt to perform the work yourself, and do so incorrectly, there is danger of poisoning caused by exhaust gases entering the building, as well as danger of water leakage, electric shock and fire.
- Installation work must be performed correctly, in accordance with the instructions listed here. Hazards from incorrect installation include dangerous exhaust gas buildup, water leakage, electric shock and fire.
- Check the type of engine fuel used. If the wrong type of gas is used, the engine can suffer combustion problems, and there is danger of poisoning caused by exhaust gases.
- Ventilate the area in case refrigerant gas leaks during installation work. If refrigerant gas comes into contact with frame during the tube brazing process, toxic gas will be produced.
- When installation work is completed, check that there is no refrigerant gas leakage. If refrigerant gas leaks into the room and contacts the frame of a fan heater, stove, burner, or other device, toxic gases will be produced.
- Never use (top up or replace) any refrigerant other than the specified refrigerant (noted on the nameplate). Doing so may cause a rupture in or breakdown of the device, or personal injury.
- When installing or moving the A/C unit, do not allow refrigerants other than the one specified (written on the label on the unit) or air to enter the unit's refrigeration cycle.
- Always use nitrogen for the airtightness test. (Do not use oxygen-based gases.)
- Never modify or repair the system yourself.



CAUTION

- When handling refrigerant gas, do not come in contact with the gas directly. Doing so may result in frostbite.

1. SELECTING THE INSTALLATION LOCATION

- (1) Install the gas heat pump A/C so that it satisfies all local regulations and government safety codes, as well as installation standards and service guidelines for industrial gas devices.
- (2) Choose a suitable installation location (with adequate space for servicing), as below.



WARNING

- Install the outdoor unit in a location where exhaust gases will not enter the building's air intake or exhaust vents or windows, and will not enter the building through tubes or vents that lead inside the building. There is danger of poisoning if exhaust gases enter the building.
- Install the outdoor unit outdoors, in a location open to the air, so that there is no accumulation of exhaust gases. There is danger of the gases entering the building and causing poisoning.
- The exhaust gases must be open to the air in a location where they will not adversely affect the surroundings. There is danger of exhaust gases entering the building and causing poisoning. (Be certain not to allow exhaust gases to be discharged into a drainage basin, gutter, or similar location.)
- Install the outdoor unit securely in a location that can fully bear the weight of the unit. There is danger of gas leakage or injury if the outdoor unit tips over or falls.



CAUTION

- When installing outdoor units, bear in mind the need of space for maintenance. Check with Fig. 1 and make sure there is enough space.
If you fail to ensure enough space, it may result in injury from falling while performing maintenance work.
- If the outdoor unit is installed on a roof or other elevated location, install a permanent ladder, handrails, and other necessary items in the passageway leading up to the unit, and install a fence, handrails, or similar structure around the outdoor unit. If such protections are not installed, an injury from falling while working may result.
- Be sure to stand on a stable surface when installing the outdoor unit on an elevated base or location, and avoid using stepladders.
- Leave the distances shown in Fig. 2 between the outdoor unit and any flammable materials. There is danger of fire if these distances are insufficient.
- Do not install the outdoor unit in a location where flammable gases may be generated, flow, accumulate or leak, or in a location where volatile substances are handled or stored. There may be danger of fire or explosion if the unit is installed in such a location.
- Install the outdoor unit in a location where exhaust gases and fan air will not harm plants or animals. The exhaust gases and fan air may adversely affect plants and animals.
- Avoid installation near locations such as parking lots and flowerbeds where damage from clinging dust and particles may occur. If installation in such locations is unavoidable, be sure to put a covering on the outdoor unit or take other measures to protect it.
- In addition to heeding the WARNING and CAUTION notes, avoid installation in locations where the unit will be exposed to the following:
 - excessive dust
 - excessively salty air, such as near the sea
 - sulfuric gases, such as near hot springs
 - excessive water, vapors, or oil fumes (ex: from machines)
 - fumes from organic solvents
 - high fluctuations in power voltage
 - electromagnetic interference from other devices
- In order to improve heat exchange, install the outdoor unit in a location that is well ventilated. Provide maintenance space and separation from flammable materials as per Figs. 1 and 2.
If installing in a poorly ventilated location, or if installing multiple outdoor units, ensure sufficient space to prevent short circuits.

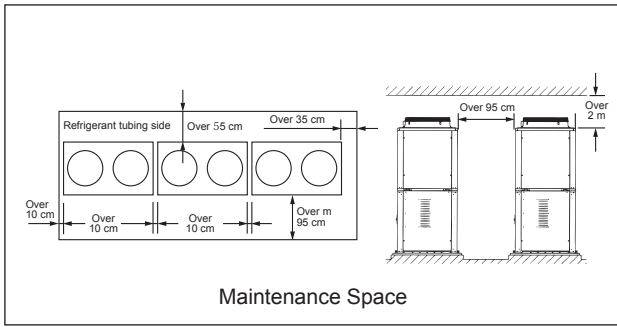

Fig. 1

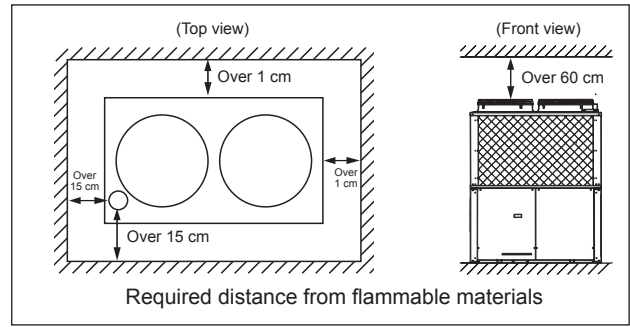

Fig. 2

- (3) In snowy regions, be sure to install a snow-protection hood and enclosure. Even in regions that do not have heavy snowfall, install a snow-protection roof (such as a snow hood) if the unit is installed in a location where snow may build up and fall from the building's roof or other surface onto the unit. (Install the hood so that the coolant supply opening at the top of the unit can be used.)
- (4) Take care that operating noise and exhaust do not disturb neighboring buildings or homes. In particular, install so that noise-related local environmental standards, if any, are satisfied at the border with a neighboring dwelling.
- (5) Because this gas heat pump A/C may affect other electrical devices with noise, give due consideration when installing AC units (both indoors and outdoors) at enough distance (at least 3 m) from the main unit of TVs, radios, stereos, intercoms, PCs, word processors, telephones, etc., as well as their antenna cables, signal wires, power cords, etc.
- (6) Select an installation location so that the length of refrigerant tubing is within the ranges shown in the table below.

Warnings (Same for All Models)

***Always use R410A branch tubes (sold separately) when running branching tubes.**

1. Warnings about using branch tubes (≡) and header tubes sold separately will come packaged with the parts sold separately, so be sure to refer to those materials.

2. When using a T-tee branch tube (provided by installer) (only with L3 at 2 m or less), the main tubing must be either level or vertical. The openings of each branch tube must be at a raised angle from the ground when the main tubing is level. The openings can be set at any angle when the main tubing is vertical, but be sure to curve a portion of the connected tubing upward. Always close weld the end point of the T-tee tubing. In addition, pay special attention to the insertion dimensions for each connected tube so that refrigerant flow is not blocked at the T-tee branches. Be sure to use only standard T-tees.

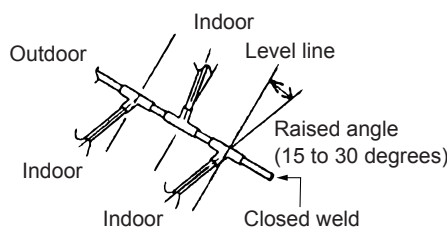

Fig. 3 Main tube (horizontal)

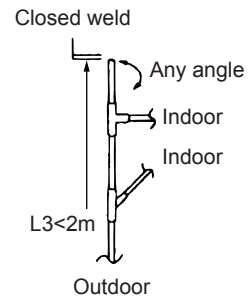

Fig. 4 Main tube (vertical)

3. Do not use off the shelf Y-joints (≡) for liquid tubes (branch tubes (made on site)).

2-Way Multi Models

Table 1-1 Ranges for Refrigerant Tubing Length and Installation Height Difference

	450	560	710	850	450×2	450+560	560×2	450+710	560+710	710×2
Equivalent Horsepower	16	20	25	30	32	36	40	41	45	50
Ratio of capacity for indoor unit to outdoor units	50 – 200%			50 – 170%	Min: Across the system, a minimum outdoor unit capacity of 50% Max: Total capacity of 130% with 2 outdoor units					
Minimum capacity of indoor units that can be connected	Type 22 or greater (equivalent to 0.8 horsepower)									
Maximum number of indoor units that can be connected (per system)	24			32	48 (A maximum of 24 indoor units can be connected per 1 outdoor unit)					

*** The number of indoor units that can be connected when a W-multi outdoor unit is installed by itself is 24 units or fewer.**

Category	Symbol	Description	Tubing length (m)
Allowable tubing length	L1	Max. allowable tubing length	≤170 (equivalent length 200)
	$\Delta L=(L2-L4)$	Difference between longest and shortest tubing lengths after the No. 1 branch (first branching point)	≤70
	LM	Max. length for main tube (tube with widest diameter)	$7 \leq LM \leq 120$
	$l1, l2...l48$	Max. length for each tube branch	≤30
	L5	Distance between outdoor units	≤7
Allowable height difference	H1	Max. height difference between indoor and outdoor units	If outdoor unit is above ≤50 If outdoor unit is below ≤35 (*1)
		H2	Max. height difference between indoor units
	H3	Max. height difference between outdoor units	1
Allowable length for branched tubing (header branch)	L3	Max. length between first T-tee branch (provided by installer) and the closed tube end	≤2

(*1) If cooling mode is expected to be used when the external temperature is 10°C or below, the maximum length is 30 m.

(*2) The max/min permissible height between indoor units (α) is found by the difference (ΔL) between the maximum length and the minimum length from the first branch.
 $\alpha = 35 - \Delta L / 2$ (however, $0 \leq \alpha \leq 15$)

● The grouping of tubes that connect the outdoor units to the indoor units is referred to as the “main tubing.”

When the maximum tubing length is more than 90 m (equivalent length), upgrade the tube size 1 rank for both the liquid and gas tubes of the main tubing.
 The prescribed performance cannot be guaranteed if the wrong size is selected.

Table 1-2 Outdoor tubing/main tubing size *1, *2

	Outdoor tubing			Main tubing						
	Outdoor unit (gross) capacity (kW)									
	45	56	71	85	90	101	112	116	127	142
Gas tube (mm)	Ø28.58 (Ø31.75)			Ø31.75 (Ø38.1)			Ø38.1			
Liquid tube (mm)	Ø12.7 (Ø15.88)	Ø15.88 (Ø19.05)		Ø19.05 (Ø22.22)						

*1 If there are plans for future expansion, choose plumbing sizes according to the total capacity after such expansion. However, if tube size is stepped up 3 levels, expansion is not possible.

*2 If the maximum tube length exceeds 90 m (or equivalent length), use the figure in parentheses () to size the main tubing, along with those of the liquid and gas tubes.
 However, size the gas tube only up to Ø38.1. (A reducer has to be fitted on-site)

Table 1-3 Main tube size after branching *1, *2

	When indoor unit(s) are connected				Main tube after branching						
	Post-branching indoor unit capacity (kW)*3										
	- 5.6	- 16.0	- 22.4	- 28.0	- 16.0	- 28.0	- 35.5	- 45.0	- 71.0	- 101.0	Over 101.0
Gas tube (mm)	Ø12.7	Ø15.88	Ø19.05	Ø22.22	Ø15.88 (Ø19.05)	Ø22.22 (Ø25.4)	Ø25.4 (Ø28.58)	Ø28.58 (Ø31.75)		Ø31.75 (Ø38.1)	Ø38.1
Liquid tube (mm)	Ø9.52			Ø9.52 (Ø12.7)		Ø12.7 (Ø15.88)		Ø15.88 (Ø19.05)	Ø19.05 (Ø22.22)		

*1 Select a diameter for the main tubing after a branch that is no larger than that of the header.
 (In cases where the main tubing after a branch would have to be larger than the header tubing, select tubing of the same size, and never exceed the header size.)

*2 If the maximum tube length exceeds 90 m (or equivalent length), use the figure in parentheses () to size the main tube after branching, along with those of the liquid and gas tubes.
 However, size the gas tube only up to Ø38.1.

*3 “- *” in the table above means “** kW or less”.

Table 1-4 Branch/Header Tube Selection

Use the following branch tubing sets or tubing sets for branching the system's main tube and indoor unit tubing.

Capacity after branch	Branch tube size ^(*)		Branch tube number		
	Gas tube (mm)	Liquid tube (mm)	Branch tubing		
			APR-P160BG	APR-P680BG	APR-P1350BG
Over 72.8 kW	Ø31.75	Ø19.05	—	—	●
Over 45.0 kW to 72.8 kW	Ø28.58	Ø15.88	—	●	●
Over 35.5 kW to 45.0 kW	Ø28.58	Ø12.7	—	●	●
Over 28.0 kW to 35.5 kW	Ø25.4	Ø12.7	—	●	●
Over 16.0 kW to 28.0 kW	Ø22.22	Ø9.52	—	●	●
Over 5.6 kW to 16.0 kW	Ø15.88	Ø9.52	●	● ^(*)	● ^(*)
5.6 kW or below	Ø12.7 ^(*)	Ø9.52	●	● ^(*)	● ^(*)

(*1) Make a selection so as not to exceed the main tubing size.

(*2) Even when 5.6 kW or below, make the gas tube diameter Ø15.88 if 2 or more indoor units are connected after branching.

(*3) As the tube diameter for the supplied reducer does not match, another reducer must be provided by the installer.

Table 1-5 Tubes Connecting Outdoor Units and Indoor Units

Outdoor Units

Tubing connecting to outdoor units (tA to tB)	Unit type	45.0 kW	56.0 kW	71.0 kW	81.0 kW
		Equivalent horsepower	16	20	25
Tube size	Gas tube (mm)	Ø28.58			Ø31.75
	Liquid tube (mm)	Ø12.7	Ø15.88		Ø19.05

Indoor Units

Tubing connecting to indoor units (tA to tB)	Unit type	22	28	36	45	56	71	80	90	112	140	160	224	280
		Equivalent horsepower	0.8	1	1.3	1.6	2	2.5	3	3.2	4	5	6	8
Tube size	Gas tube (mm)	Ø12.7						Ø15.88				Ø22.22	Ø25.4	
	Liquid tube (mm)	Ø6.35				Ø9.52				Ø12.7				

Note: Keep the maximum length between t1 to t48 within 30 m.

- LM: Main tube with largest tubing diameter (includes LA and all post-branch main tubes that are identical in size to LA) ≤ 120 m.
- Select the sizes for post-branching main tubes after LM (LB, LC, ...) based on the post-branching capacity.
- The sizes for the indoor unit connection tubing (t1 to t48) depend on the tubing diameter for the indoor unit.

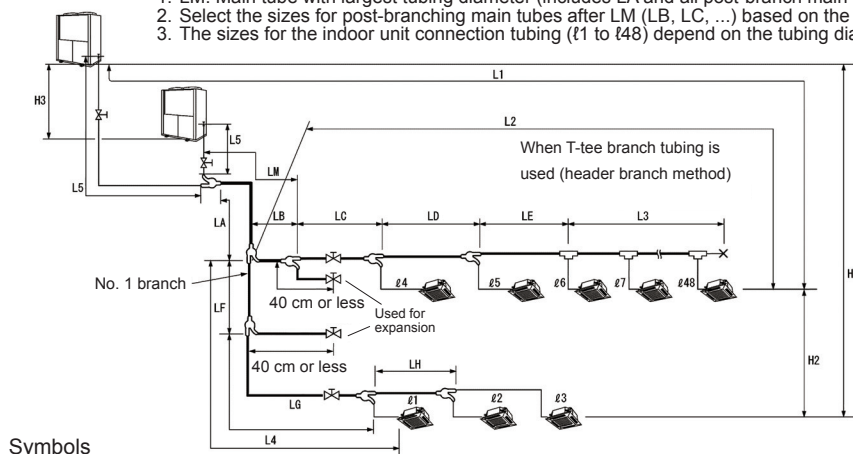

Symbols

- ↔: Branch tube (APR purchased separately)
- ⊗: Ball valve (purchased separately)
- ⊕: T-tee (provided by installer)
- ×: Closed (pinch) weld

Maximum height differential of indoor units after final branch
Four meters is the maximum height differential between indoor units after the last branch.

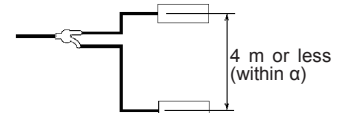

If exceeding the 4 m of height between indoor units after a final branch cannot be helped, split the difference between rise and fall (2:1).

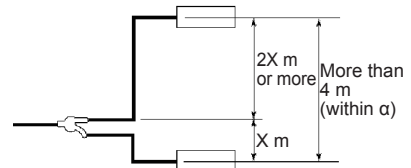

Fig. 5 Length of Refrigerant Tubing

3-WAY Multi Models

Table 2-1 Refrigerant tubing length and range of rise/fall

Indoor unit		45.0 kW	56.0 kW	71.0 kW
Capacity proportion of the indoor units to the outdoor unit		50 - 200 %		
Minimum capacity of indoor units that can be connected		≤ 22 type (equivalent to 0.8 horsepower)		
Maximum number of indoor units (systems) that can be connected		24		
Maximum allowable tubing length (L)		L ₁	≤ 120 m (equivalent length ≤ 145 m) ^{(*)1}	
Difference between longest and shortest tubing lengths after the No. 1 branch (first branching point)		L ₂ - L ₈	≤ 30 m	
Maximum length of each tube branch		ℓ ₁ , ℓ ₂ ...ℓ ₈	≤ 30 m	
Maximum allowable height difference between indoor and outdoor units	If outdoor unit is above	H ₁	≤ 50 m	
	If outdoor unit is below	H ₂	≤ 35 m ^{(*)2}	
Maximum allowable height difference between indoor units		H ₃	≤ 15 m ^{(*)3}	
Maximum length from the first T-tee to the last T-tee		L ₃	≤ 2 m	

(*1) The minimum length of tubes between outdoor units and indoor units is 7 m.

(*2) If cooling mode is expected to be used when the external temperature is 10°C or below, install so the maximum length is 30 m.

(*3) Install so that the height difference between indoor units after the final branch is within the limits shown in Fig 3.

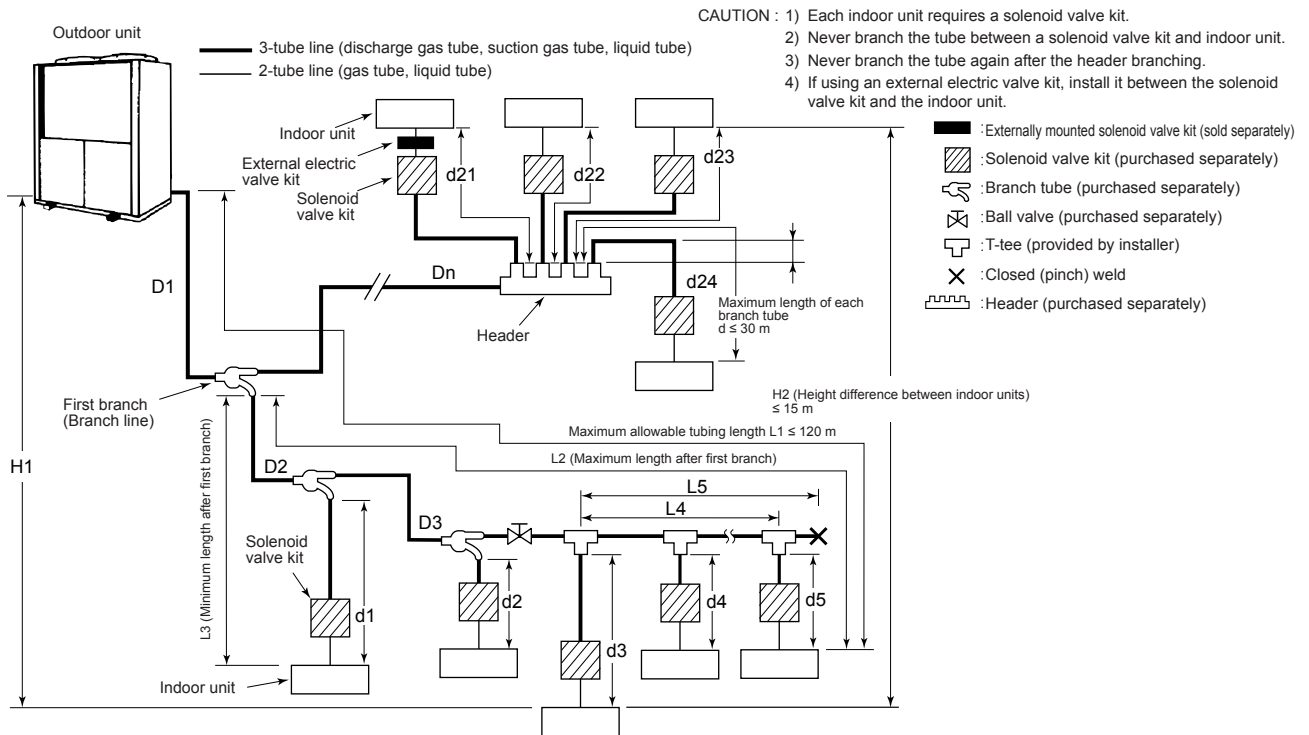

Maximum height differential of indoor units after final branch

Height difference between indoor units after the final branch must be less than 4 m.

If height difference between indoor units after the final branch cannot be less than 4 m, divide the height difference between upper and lower units (2 to 1).



Fig. 6 Length of Refrigerant Tubing

Table 2-2 Main tubing size after distribution (D2, D3, Dn)

Outdoor unit	Outdoor tubing (mm)		Post-branch main tubing				
			Total capacity for connected indoor units (kW)				
			35.6 to 142.0	28.1 to 35.5	16.1 to 28.0	9.0 to 16.0	Under 9.0
45.0 kW	Suction tube	Ø28.58 (Ø31.75)	Ø28.58 (Ø31.75)	Ø28.58	Ø25.4	Ø19.05	Ø15.88
	Discharge tube	Ø22.22	Ø22.22	Ø22.22	Ø19.05	Ø15.88	Ø12.7
	Liquid tube	Ø19.05	Ø15.88	Ø15.88	Ø12.7	Ø9.52	Ø9.52
56.0 kW	Suction tube	Ø28.58 (Ø31.75)	Ø28.58 (Ø31.75)	Ø28.58	Ø25.4	Ø19.05	Ø15.88
	Discharge tube	Ø25.4	Ø25.4	Ø22.22	Ø19.05	Ø15.88	Ø12.7
	Liquid tube	Ø19.05	Ø19.05	Ø15.88	Ø12.7	Ø9.52	Ø9.52
71.0 kW	Suction tube	Ø28.58 (Ø31.75)	Ø28.58 (Ø31.75)	Ø28.58	Ø25.4	Ø19.05	Ø15.88
	Discharge tube	Ø25.4	Ø25.4	Ø22.22	Ø19.05	Ø15.88	Ø12.7
	Liquid tube	Ø19.05	Ø19.05	Ø15.88	Ø12.7	Ø9.52	Ø9.52

- *1 If anticipating future expansion, select tube diameters according to total capacity after expansion.
- *2 If the maximum tubing length exceeds 90 m (equivalent length), increase the diameter of the main tubing to the size in () for both liquid and gas tubes. However, gas tube diameter should not exceed 31.75 mm. (Reducers are available locally.)
- *3 “-*” in the table above means “** kW or less”

Table 2-3 Branching⇔solenoid valve kit tubes<3-tube side>

Tubing size (mm)	Suction tube	Ø15.88
	Discharge tube	Ø12.7
	Liquid tube	Ø9.52

Table 2-4 Solenoid valve kit⇔indoor unit tubes <2-tube side>

Indoor unit	Unit Type	22-56 kW	71-160 kW
		Equivalent Horsepower	0.8-2.0
Tubing size (mm)	Gas tube	Ø12.7	Ø15.88
	Liquid tube	Ø6.35	Ø9.52

(7) Plumbing separately purchased goods

• **Gas Cut-off Valve Kit (for 2-WAY multi)**

• SGP-VK32K

The gas cut-off valve kit is installed in the refrigerant gas tubes (largest tube) between the main tube and outdoor units, as shown in Fig. 7.

* If a vibration-resistant frame is to be used, refer to the chapter, using a Vibration-Resistant Frame.

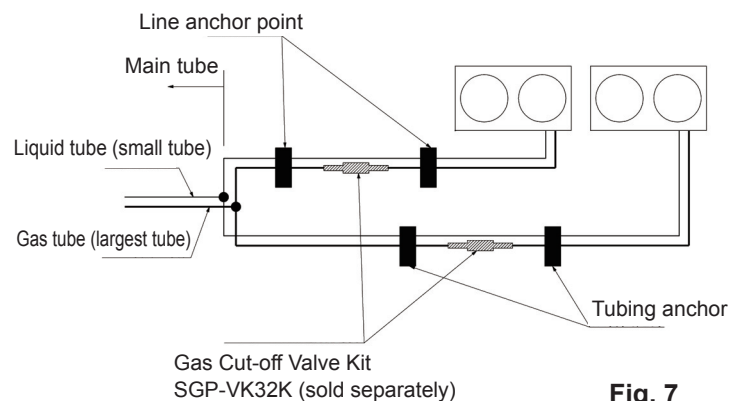

Fig. 7

• **Solenoid Valve Kit (for 3-WAY multi)**

- ATK-RZP56BGB
- ATK-RZP160BGB

- ① Install the solenoid valve kit at a point within 30 m of the indoor unit.
- ② For places where quiet is an important consideration, such as hospitals, libraries, hotels, etc., we recommend installing the solenoid valve kit away from rooms, such as in the ceilings of hallways, to avoid annoyance due to refrigerant noise.
- ③ Install an inspection port near the solenoid valve kit so it can be serviced.

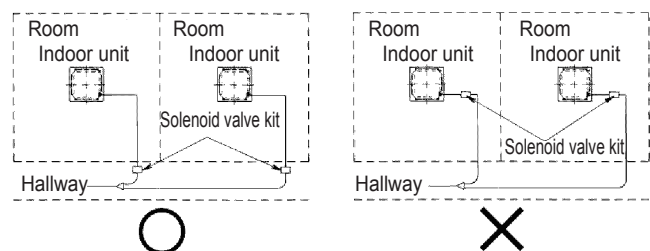

Fig. 8

(8) Check the threshold concentration



WARNING

The refrigerant (R410A) used in a multi-unit air conditioning installation is in itself a safe refrigerant that is neither flammable nor poisonous, but just in case a leak in a small room should occur, steps need to be taken to prevent gas from exceeding the permissible concentration and causing asphyxiation. The Japan Refrigeration and Air Conditioning Association have stipulated a threshold concentration for refrigerants in its publication “Guidelines for Ensuring Safety in the Event of a Refrigerant Leak from a Multi-Unit Air Conditioning System” (JRA GL-13:2010).

Apart from the lowest level underground, the threshold concentration for the charge in a system has been set to

total refrigerant/living space capacity $\leq 0.42 \text{ kg/m}^3$ (R410A models).

If this condition is not met, the system must either be equipped with two of the countermeasures (alarm, ventilation or safety shut-off valve) or be redesigned.

Please note, when the system is in the lowest level underground, depending on the type of refrigerant, the threshold concentration and number of countermeasures required may vary.

For further details, either refer to the technical document JRA-GL-13 or consult with your dealer.

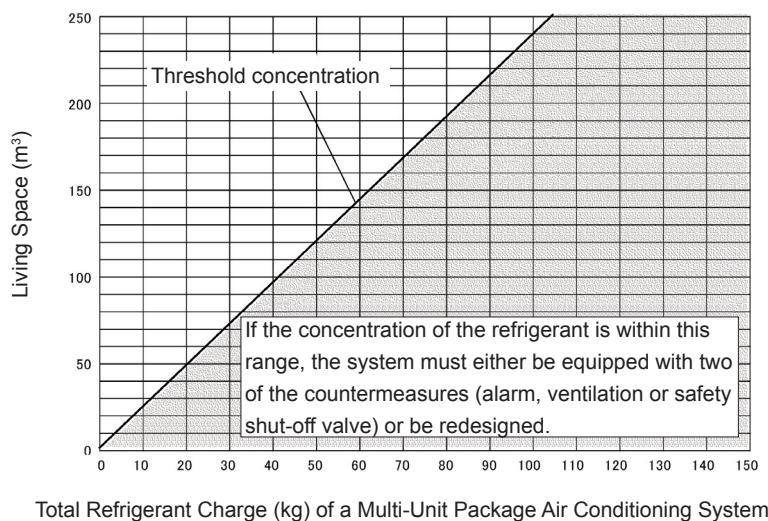

Fig. 9 Permissible Refrigerant Charge for Specific Systems and their Required Countermeasures (R410A Refrigerant)
<Not Including Lowest Level Underground>

2. PRECAUTIONS FOR INSTALLATION WORK

(1) Foundation construction



WARNING

- The foundation for the outdoor A/C unit must be made of concrete or similar material, and must be sturdy and level, with good drainage. Imperfections may cause the outdoor unit to turn over, resulting in gas leakage and/or injury.
- Use a level to make sure the foundation is level. If level is not maintained, it may result in a breakdown.
- When installing the outdoor unit, be sure to use the specified size of anchor bolts (shown in Fig. 10) and anchor the unit security. Failure to do so may result in the outdoor unit tipping over, causing gas leakage and personal injury.
- Spread a vibration-resistant mat over the surface where the bottom of the outdoor unit contacts the ground, so that the load is applied evenly. Use rubber bushings and anchors in such a way does not diminish the vibration-resistant effects.

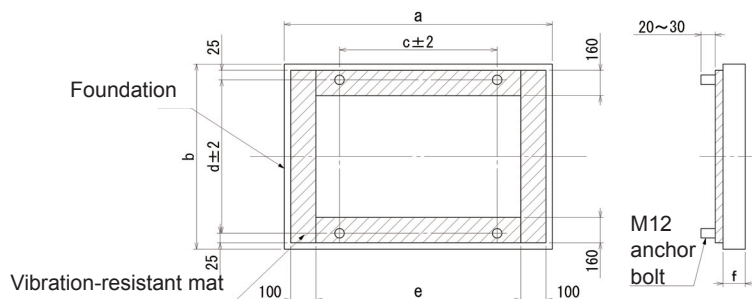

Unit: mm

Fig. 10 Foundation diagram (mat foundation)

Table 3

		a (mm)	b (mm)	c (mm)	d (mm)	e (mm)	f (mm)	
45.0/56.0/ 71.0 kW	Installation on ground	1,700 or more	1,170 or more	1,000	1,040	1,450	120 or more	
	Installation on roof	Without vibration-resistant frame	1,850 or more				2,000 or more	140 or more
		With vibration-resistant frame (single type)	2,000 or more					
		With vibration-resistant frame (interlocking type)	1,850					
85.0 kW	Installation on ground	1,700 or more	1,170 or more	1,000	1,040	1,450	120 or more	
	Installation on roof	Without vibration-resistant frame	1,850 or more				2,000 or more	140 or more
		With Vibration-resistant frame	2,000 or more					

Unit: mm

- Be sure to take the following steps to prevent shifting of the foundation. A mat foundation that is simply placed on a floor slab (A-a type) must be of the dimensions shown in the Table 3 or larger in order to prevent shifting of the foundation in case of earthquake. If the mat foundation is smaller than these dimensions, take steps such as connecting the foundation and the building structure with reinforcing bars, in accordance with building utilities earthquake-resistant design and construction guidelines. Foundation types A-b, A-c, A-d, and A-e are provided as examples.
- Use one of the following types of anchors. Use bolts of size M12 or larger for all bolts.
 1. Embedded-type: L-type, LA-type, headed bolts, J-type, JA-type
 2. Blockout-type: L-type, LA-type, headed bolts, J-type, JA-type (Make dimension "f" of the foundation 180 mm or more.)
 3. Plastic anchor
 4. External-thread type mechanical anchor

CAUTION: Do not use an internal-thread type mechanical anchor.

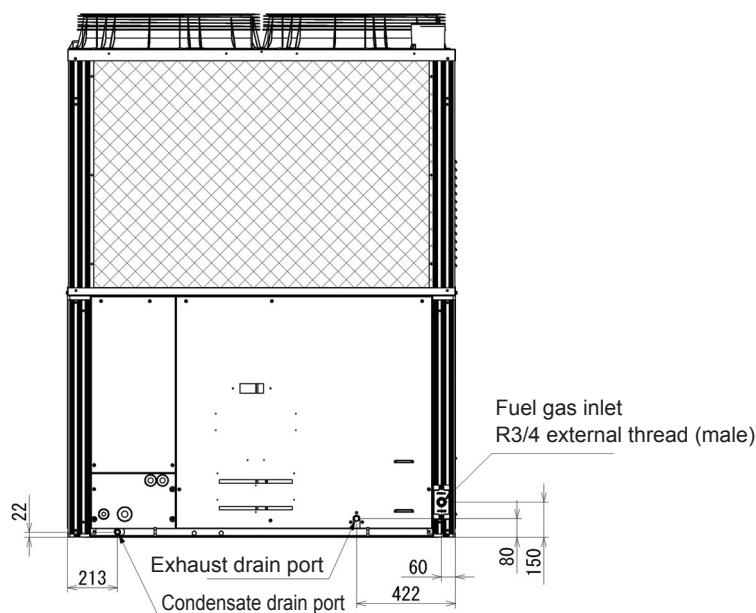

Unit: mm

Fig. 11

(2) Fuel piping work

As needed, attach devices ②, ③ or ⑤ to the outdoor unit external fuel gas pipe. (Fig. 12-1)

① Flexible gas hose ② Pressure release tap ③ Strainer ④ Master valve ⑤ Pipe bracket

A main valve must be installed for servicing the fuel gas tube.



CAUTION

- Use a reinforced gas hose or a low-pressure gas hose with fuel gas joint bracket between the fuel gas pipe master valve and the outdoor unit. In addition, avoid excess pressure or shock to the outdoor unit's fuel gas inlet by taking measures such as making the pipe path leading up to the gas hose as short as possible. Otherwise, there is danger of fire resulting from fuel gas leakage.
- If necessary, install pipe brackets in the fuel gas pipe path to reduce the risk of pressure or shock to the pipe path. In particular, take sufficient precautions when installing near roads. There is a danger of fire or explosion resulting from fuel gas leakage.
 - * In regions with heavy snowfall, take precautions to protect the fuel gas pipe path from snow damage (Fig. 12-2).
- After installation work is completed, check that there is no gas leakage from the fuel gas pipe/hose path. There is danger of fire resulting from fuel gas leakage.
- To ensure safety in case of a gas leak, make sure that airflow surrounding the outdoor unit is sufficient and gas will not accumulate. Accumulation of gas may result in fire or explosion.

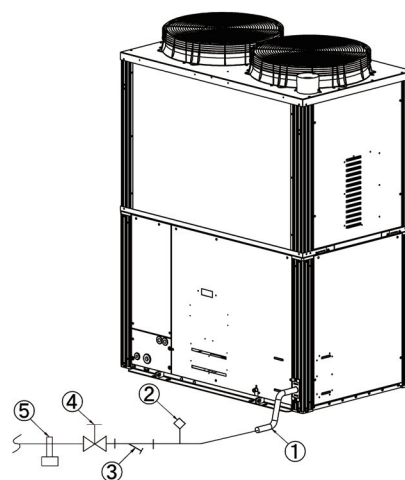

Fig. 12-1 Fuel Pipe Structure Diagram

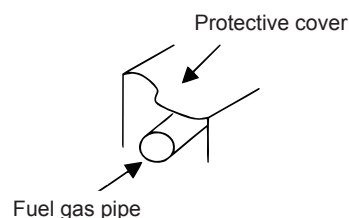

Fig. 12-2 Fuel pipe protection example

(3) Exhaust drain pipe work

Attach the included exhaust drain hose to the exhaust drain port (Fig. 11) and follow the precautions below in performing plumbing work.

- The exhaust drain hose comes packaged on the reverse side of the electrical box panel of the outdoor unit.



WARNING

- If connecting the outdoor unit's exhaust drain to a covered drainage basin or gutter, or draining multiple outdoor units to the same location, be sure to configure the pipes (as shown in Fig. 13) so that exhaust gases are discharged into open air. (Make sure that the opening in the receiving drain pipe is at least 50A in nominal diameter.) Exhaust gases flowing into the building or indoor/outdoor units may result in poisoning or corrosion of the unit.
- If a pipe is used for outdoor unit exhaust draining, do not use the same pipe for other purposes (condensate draining for outdoor units, indoor unit draining, etc.). Exhaust gases flowing into the building or indoor/outdoor units may result in poisoning or corrosion of the unit.



CAUTION

- If installing the outdoor unit on a roof, extend the exhaust drain pipe to the water drain (as shown in Fig. 14).
PROHIBITED: Do not install the drain pipes so they drain directly onto concrete surfaces, waterproof sheets, or metal roofing. Doing so may result in discoloring of concrete and metal surfaces, damage to waterproof sheets, holes, and other damage.
- Fasten the exhaust drain hose (included) with a hose clamp.
If the exhaust drain hose leaks, it may cause corrosion to the equipment.
- When installing the exhaust drain hose (included) and plumbing the exhaust drain water tube, take care that it is not blocked from bending/smashing the exhaust drain hose.
If the exhaust drain hose is blocked, it will result in poor engine combustion and may lead to an equipment breakdown.
- Slope the drain pipe at a gradient of 1/50 or more, and do not taper the pipe diameter (Fig. 13, 14). In addition, do not create any traps or peaks in the pipe.
- If connecting multiple outdoor units to a single exhaust drain pipe, be sure to prevent exhaust gases from flowing backward by allowing the gases to discharge into open air where the drain hose enters the drain pipe (with the drain pipe opening at least 50A in nominal diameter). Exhaust gases flowing back into the outdoor units while they are stopped may result in starting failures, engine stalls, corrosion of the unit, and other problems. In addition, take measures to prevent drain water from splattering in locations where wind is strong.
- In cold regions where the exhaust drain pipe is likely to freeze, wrap heat tape or take other measures to prevent freezing.
- Use PVC or stainless steel tubing for the exhaust drain pipe.
- As condensed water drips from the unit, be sure to install it in a location with good drainage. (Tubing for the condensate drain port (Fig. 11) is not necessary, but follow the above precautions if tubing is installed.)
* Condensed water from the refrigerant tubing inside the unit is released through the condensate drain port. Condensed water from the heat exchanger and water that gets inside the unit is released through the drainage ports located at the center of either side panel.

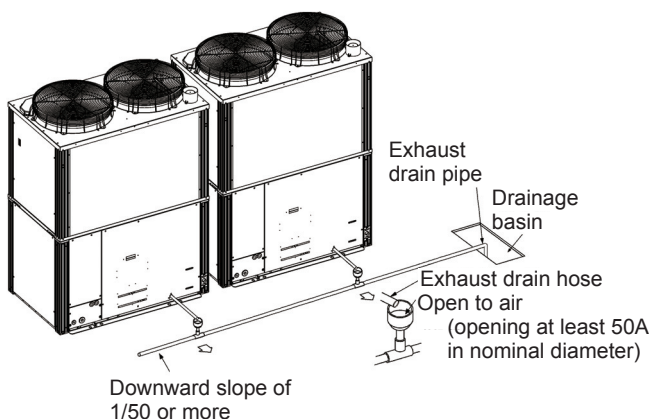

Fig. 13 Draining the exhaust into a drainage basin

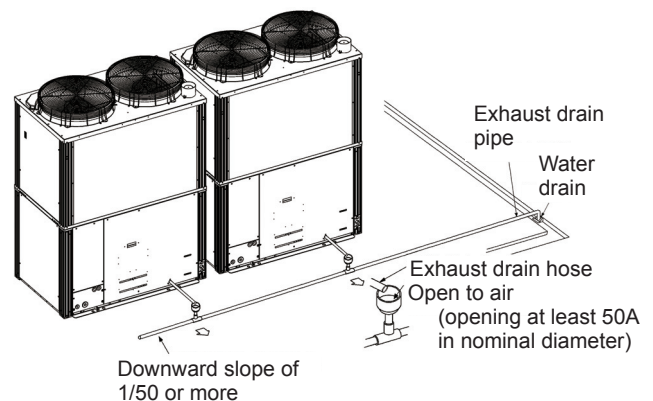

Fig. 14 Draining the exhaust into a water drain (roof)

3. INSTALLATION PROCEDURE

3-1. Anchoring the outdoor unit

Transporting the outdoor unit by hoist:

- For hoisting, pass the rope over the hoisting brackets on the unit vase at 4 locations. (Fig. 15)
- Insert wood separators as protective shielding when using the hoist to prevent the outer casing from being scratched or deformed by the rope. Be sure not to touch or apply pressure on tube connectors. (Fig. 15)
- When hoisting with a crane, the crane hook position must be 1 m or more above the unit.

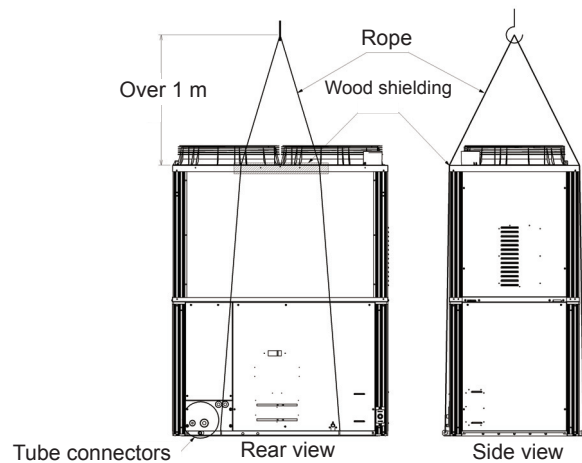

Fig. 15



CAUTION

- Do not lay the outdoor unit on its side during transportation. This can damage the devices and result in malfunction.

3-2. Preparing and installing the tubing

- Material: Phosphorous deoxidized copper seamless tubing (C1220T)
- Tubing size: Choose tubing sizes according to tables 1-2, 1-3, 1-5, and 2-2 to 2-4.
Use tube with thickness as per Table 4.

Table 4

Tubing size (mm)		
Exterior diameter	Wall thickness	Type
Ø9.52	T0.8	O
Ø12.7	T0.8	
Ø15.88	T1.0	
Ø19.05	T1.0	1/2 H or H
Ø22.22	T1.0	
Ø25.4	T1.0	
Ø28.58	T1.0	
Ø31.75	T1.1	
Ø38.1	T1.35	

- After cutting the tube, be sure to remove all burrs and finish tubing ends to the correct surface. (The same must be done for branch tubes (purchased separately).)
- When bending tubes, be sure the bend radius is at least 4 times the outer diameter of the tube.
- When cutting or bending tubes, be careful not to cause any pinching or blockage of the tube.

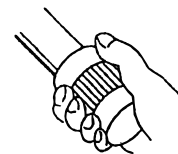

Fig. 16



CAUTION

- Prevent foreign substances such as dirt or water from entering the tube by sealing the end of the tubes with either a cap or with tape. Otherwise, this can damage the devices and result in malfunction.

3-3. Connecting the refrigerant tubing

1. Remove the rubber washers on the gas and liquid tubes from the pipe connection panel.
2. Connect the tubes and perform brazing.
3. Reattach the gas tube, liquid tube fastening panel, and fastening rubber as they were originally.

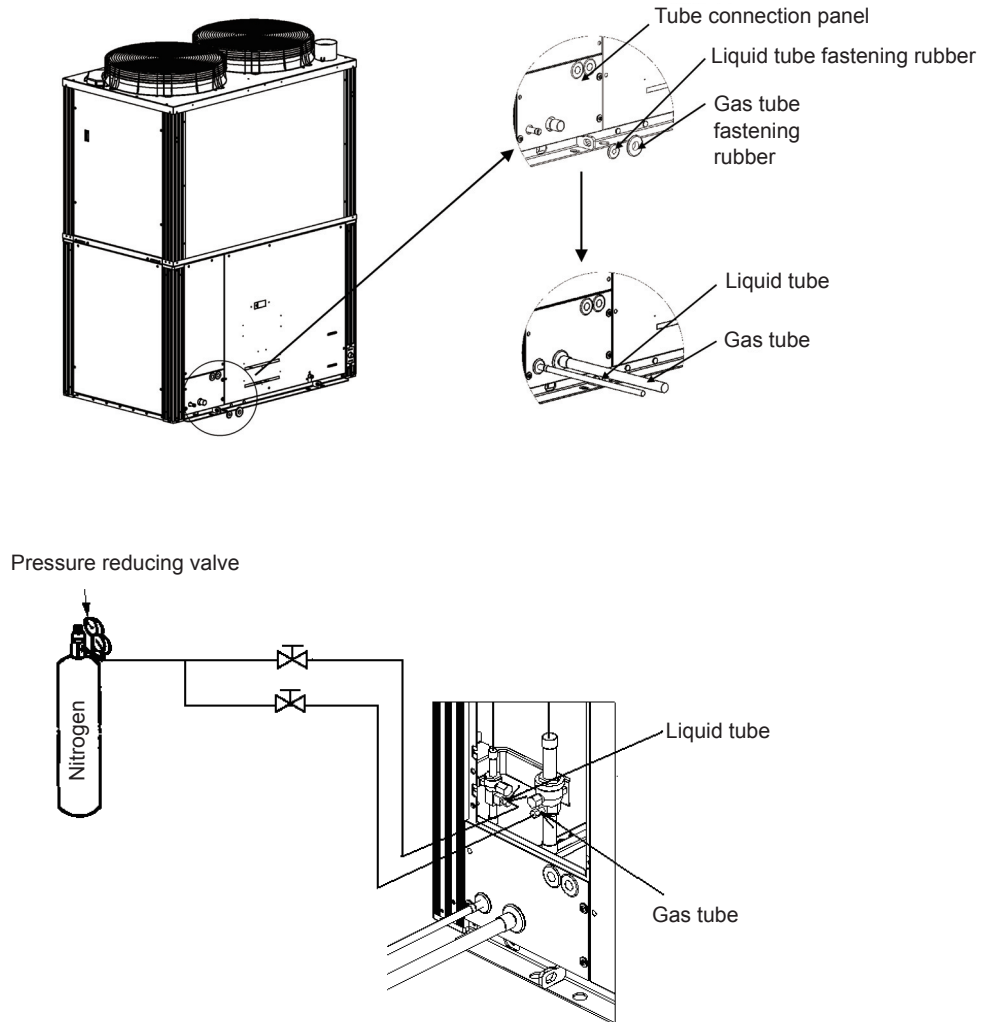

Fig. 17



Be sure to perform the following before brazing.

- The rubber that fastens the tubes is damaged easily by heat. Be sure to remove it before brazing.
 - Cool the tubes with wet cloths or other materials to prevent the valve inside the machine from being damaged by the brazing heat.
 - Be sure to replace the contents of the tube with nitrogen to prevent the formation of an oxide film. (Oxygen, carbon dioxide or refrigerant may not be used)
 - Do not use commercially available oxide film agents (antioxidants). They can adversely affect the refrigerant and the refrigeration oil, and can cause malfunctions.
 - If using flare connections (for the indoor connectors or other part), apply refrigeration oil to the flared part.
- * With a 3-way multi system, there will be 3 tubes. Treat each of the tubes in the same way.

3-4. Tubing airtightness test and vacuum application

An airtightness test is required for gas heat pump A/C as part of industry installation guidelines. Follow the procedure below to perform the test and confirm there is no leakage from any connections.

- Connect the manifold gauge to both service ports - on the wide tube side and narrow tube size. Then connect the nitrogen tank, vacuum pump, and other items as shown in Fig. 18.

CAUTION

Connect an R410A control valve (Schrader valve) at the service port for the shut-off valve. If an R410A control valve (Schrader valve) is not connected, it may cause a frost burn due to refrigerant leaking when the charge hose is removed.

	<p>CAUTION</p>	<p>Use nitrogen to raise the pressure to the airtightness test pressure (4.15 MPaG) and confirm that there is no leakage. Refrigerant leakage can cause suffocation and injury to nearby persons.</p>
---	-----------------------	---

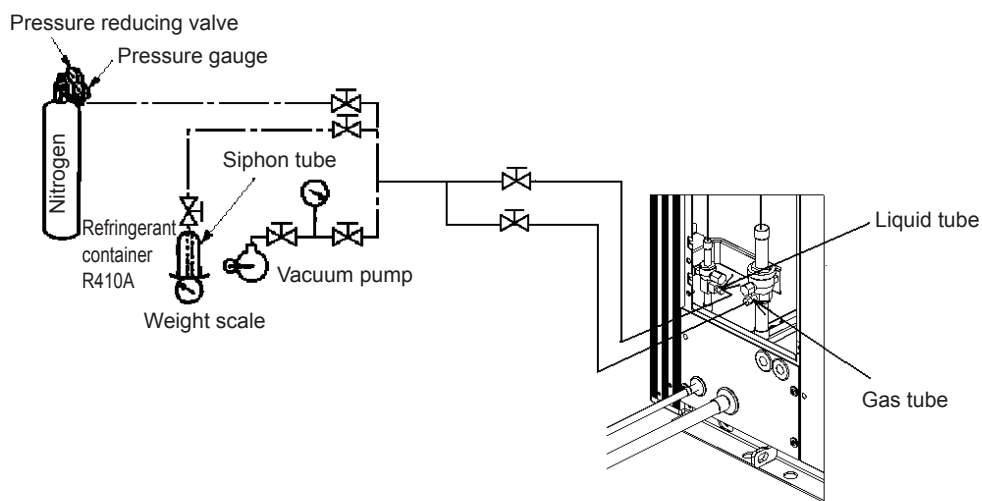

Fig. 18

- When checking for air/vacuum tightness, do so at all service ports at the same time. (With all the valves to the outdoor units closed.)
Always use nitrogen when performing air tightness checks.
(Oxygen, carbon dioxide or refrigerant may not be used)
When performing air tightness checks on the tubes between indoor/outdoor units, we recommend doing so on the tubes independently, prior to connecting outdoor units.
- After the airtightness test is completed, apply vacuum of 667 Pa (-755 mmHg, 5 Torr) or below to the indoor unit and tubing.
- Do not leave for a long period of time after the vacuum state has been reached.

CAUTION

There is a check valve at each service port.

* With a 3-way multi system, there will be 3 tubes. Treat each of the tubes in the same way.

3-5. Refrigerant charge

Calculation of amount of additional refrigerant charge

- Table 6 shows the refrigerant charge at factory shipping time. Additional refrigerant must be added according to the size and length of the tubing. If a water heat exchanger unit is installed, provide an additional refrigerant charge for the connecting line portion. (Use the values in Table 5 to calculate liquid tube size and length.)

Table 5 Quantity of additional refrigerant charge

Liquid tube size (mm)	Additional charge quantity per meter (g/m)
Ø6.35	26
Ø9.52	56
Ø12.7	128
Ø15.88	185
Ø19.05	259
Ø22.22	366

Table 6

Type	Quantity of refrigerant charge when shipped (kg)
45.0 kW	10.5
56.0 kW	11.5
71.0 kW	
85.0 kW	

$$\text{Required additional refrigerant charge (g)} = 456 \times (A) + 366 \times (B) + 259 \times (C) + 185 \times (D) + 128 \times (E) + 56 \times (F) + 26 \times (G) + \text{Unit additional charge amount (H)}$$

- (A) = total length in meters of 25.4 mm diameter liquid tubing
- (B) = total length in meters of 22.22 mm diameter liquid tubing
- (C) = total length in meters of 19.05 mm diameter liquid tubing
- (D) = total length in meters of 15.88 mm diameter liquid tubing
- (E) = total length in meters of 12.7 mm diameter liquid tubing
- (F) = total length in meters of 9.52 mm diameter liquid tubing
- (G) = total length in meters of 6.35 mm diameter liquid tubing
- (H) = Unit additional charge amount (Table 7)

Table 7

Type	Unit additional charge amount (kg)
45.0 kW	—
56.0 kW	0.5
71.0 kW	2.5
85.0 kW	11.0* ¹

*1 When connecting a water heat exchange unit, the value is 10.0 kg.

- Be careful to charge accurately according to refrigerant weight.
- Charging procedure
Evacuate the system, close the gauge manifold at the gas tube side to ensure that no refrigerant enters the gas tube side, then charge the system with liquid refrigerant at the liquid tube side. While charging, keep all valves fully closed. The compressor can be damaged if liquid refrigerant is added at the gas tube side.
- If the system does not accept the predetermined quantity of refrigerant, fully open all valves and run the system (either heating or cooling). While the system is running, gradually add refrigerant at the low pressure side by slightly opening the valve on the cylinder just enough so that the liquid refrigerant is gasified as it is sucked into the system. (This step is normally only needed when commissioning the system.)
All outdoor unit valves should be fully open.
- When charging is completed, fully open all valves.
- Avoid liquid back-flow when charging with R410A refrigerant by adding small amounts at a time.

CAUTION

- When charging with additional refrigerant, use liquid only.
- R410A cylinders are colored gray with a pink top.
- Check whether a siphon tube is present (indicated on the label at the top of the cylinder).
- Depending on refrigerant and system pressure, conventional refrigerant (R22, R407C) equipment may or may not be compatible with R410A equipment, so care is needed. In particular, the gauge manifold used must be specifically designed for R410A.
- Be sure to check the limiting density.
- Refer to the section “4. OPENING THE CLOSED VALVES” (→ page 17) when the instructions call for fully opening all valves.

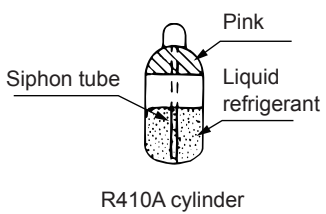

3-6. Finishing the outer tubing covering



- Insulate absolutely all of the tubes to units, including branch tubes. The surface of insulating materials is subject to condensation, especially in a hot, humid environment, so choose insulation that is thick enough, as per JIS A 9501. Further, fill in any gaps to prevent moisture from getting in at the ends and joints of the insulation. If not enough insulation is used, it may result in leaking or dripping water. The criteria for selecting insulation are provided in the installation planning guide, so refer to it in selecting materials. Use insulation for gas tubes that is heat resistant to at least 120°C and at least 80°C for liquid (and suction tubes) tubes.
- Use separate piping for the power cables and the control cables. If the cables are passed through the same pipes, the effects of electrical noise and induction can cause malfunctions.

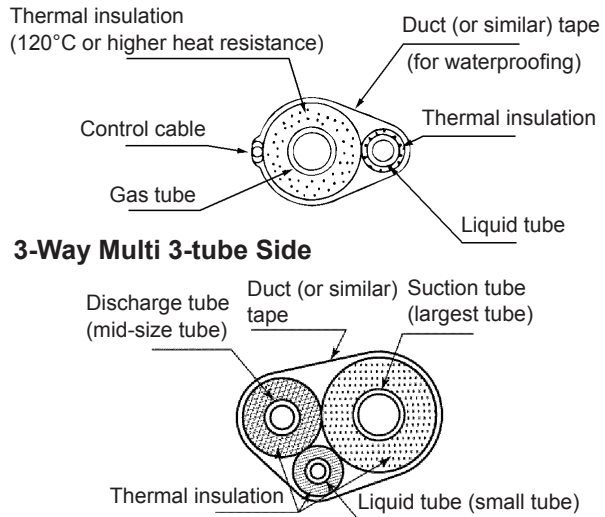

Fig. 19

4. OPENING THE CLOSED VALVES

Ball valves are used for the closed valves on the outdoor unit. Each can be opened and closed by rotating the tab 90 degrees. Follow the procedure below to securely open the valves.

1. Remove the cap.
2. Slowly and securely turn the tab to the left (counterclockwise) 90 degrees. The valve is fully open when the tab has been rotated 90 degrees (when it contacts the stopper). Do not forcefully attempt to turn the tab past this point.

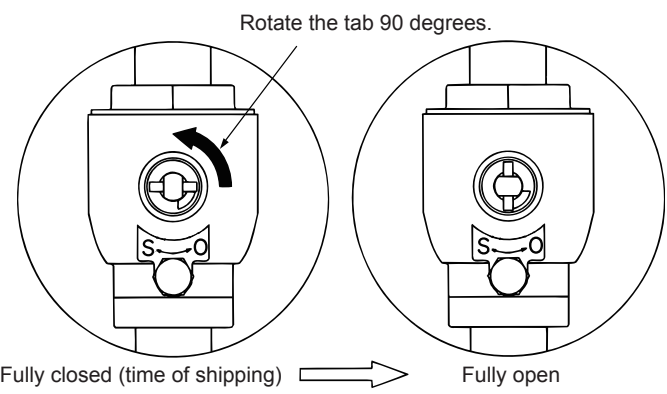

Fig. 20 Rotating the Tab

CAUTION

Be sure to open the closed valve all the way.

3. Reattach and tighten the cap.

- Cap tightening torque
 - Liquid side (45.0 kW) 13 N·m
 - Liquid side (56.0 - 85.0 kW) 30 N·m
 - Gas side (45.0 - 85.0 kW) 30 N·m
- <3WAY>
 - Liquid side 13 N·m
 - Suction gas side 30 N·m
 - Discharge gas side 30 N·m

5. AFTER INSTALLATION IS COMPLETED

- Record the actual length of refrigerant tubing and the amount of refrigerant charge. With the outdoor unit, the “label for showing the actual length of refrigerant tubing and the amount of refrigerant charged” is provided. Enter the details in the designated spaces, and apply the label to the inside of the electrical box panel, at the top.

**This will be needed for subsequent maintenance.
Be sure to enter this information and apply the label.**

6. ENGINE REPLACEMENT PATHWAY

- During installation, consider the engine external dimensions listed at right and ensure that there is a sufficient pathway for moving the engine.

This pathway will be required should the engine need to be replaced.

Table 8

Engine external dimensions (mm)			Package weight (kg)
Width	Depth	Height	
670 (810)	640 (760)	650 (700)	170

* Figures in parentheses are the external dimensions of the wood shipping crate.

7. USING A VIBRATION-RESISTANT FRAME

- A vibration-reduction frame must be used if the unit is installed in locations where noise and vibration can be a problem, such as on rooftops above living spaces or conference rooms. If a vibration-resistant frame is used, be sure to install steady braces or other support, and take measures to prevent applying excessive force to the refrigerant tubing.
- Refer to the instruction manual supplied with the vibration-resistant frame when installing the frame.

(1) When Using Singular Frames

- When anchoring the refrigerant tubing, be sure to set the tubing anchor for each outdoor unit at least 1.5 m away from the respective unit (as shown in Fig. 21-1).
- When installing a ball valve, be sure to install them within area B. (Installation in area A is prohibited.)

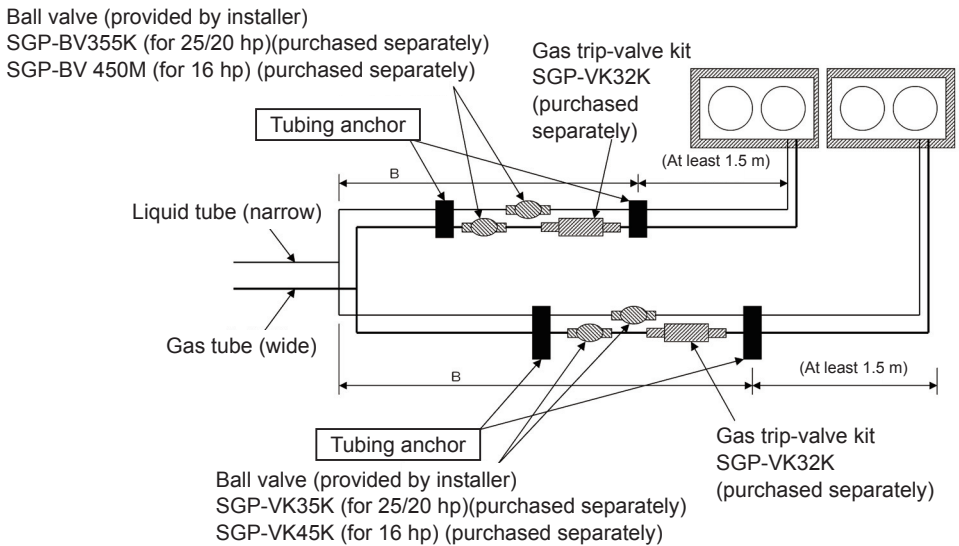

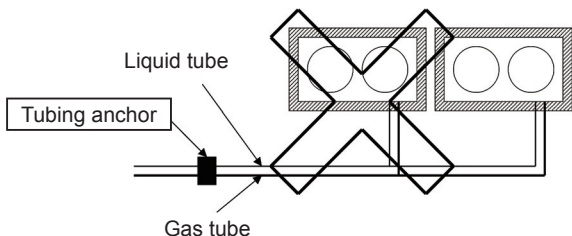

Fig. 21-1



CAUTION

When using single-type vibration-resistant frames, never install tubing in the manner shown at the right. Doing so puts excessive weight on the entire tubing installation and may result tube damage.



Liquid tube

Tubing anchor

Gas tube

Fig. 21-2

(2) When Using Interlocking Frames

- When using interlocking vibration-resistant frames, always use frames designed for use with the GHP-W Multi series.
 - * There is no vibration-resistant frame for connected types of units compatible with U-30GE2E5 or U-30GEP2E5.
 - After installing the frame, be sure to install steady braces or other support, and take measures to prevent applying excessive force to the refrigerant tubing.
 - If installing gas trip-valve kits or ball valves to each outdoor unit, be sure to install them on the vibration-resistant frame. (Installation on the ground is prohibited.)
 - When anchoring the refrigerant tubing, always anchor the tubing at the main tubing to prevent tube damage from excessive weight.
- When determining the anchor position, refer to the dimensions for A in Fig. 22.

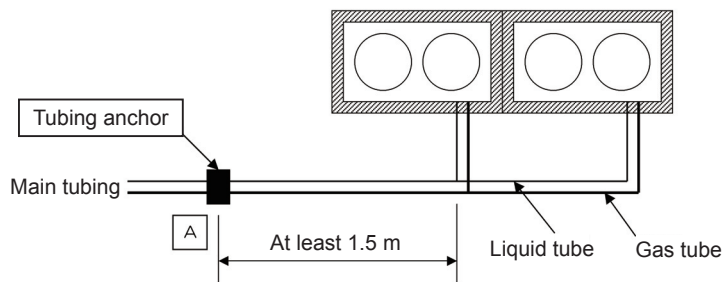

Fig. 22

– NOTE –

Compliance with regulation 842/EC/2006 Article 7(1) requirements

EN DO NOT VENT R410A INTO THE ATMOSPHERE: R410A IS A FLUORINATED GREENHOUSE GAS, COVERED BY THE KYOTO PROTOCOL, WITH A GLOBAL WARMING POTENTIAL (GWP) = 1975.

Conformité aux exigences de l'article 7 (1) de la réglementation 842/EC/2006

FR NE PAS METTRE LE R410A À L'AIR LIBRE: LE R410A EST UN GAZ À EFFET DE SERRE FLUORÉ, RÉGULÉ PAR LE PROTOCOLE DE KYOTO AVEC UN POTENTIEL DE RÉCHAUFFEMENT DE LA PLANÈTE (GWP) = 1975.

Kompatibilität mit den Anforderungen der Vorschrift 842/EC/2006, Artikel 7 (1)

DE R410A NICHT IN DIE AUSSENLUFT ABLASSEN: R410A IST EIN FLUORIERTES TREIBHAUSGAS, DAS IM KYOTO-PROTOKOLL ENTHALTEN IST UND EIN ERDERWÄRMUNGSPOTENTIAL (GWP) VON 1975 AUFWEIST.

Osservanza delle richieste dell'Articolo 7(1) delle regolamentazioni 842/EC/2006

IT NON DISPERDERE R410A NELL'ATMOSFERA: L'R410A È UN GAS FLUORATO CAUSA DI EFFETTO SERRA E COPERTO DAL PROTOCOLLO DI KYOTO CON UN POTENZIALE DI RISCALDAMENTO GLOBALE (GWP) = 1975.

Conformidade com o regulamento 842/EC/2006 Requisitos do Artigo 7(1)

PT NÃO DEIXE O R410A ESCAPAR PARA A ATMOSFERA: O R410A É UM GÁS FLUORADO COM EFEITO DE ESTUFA, REGULADO PELO PROTOCOLO DE QUIOTO, COM UM POTENCIAL DE AQUECIMENTO GLOBAL (GWP) = 1975.

Cumplimiento de los requisitos del Artículo 7 (1) de la Directiva 842/EC/2006

ES NO LIBERAR R410A AL AIRE LIBRE: EL R410A ES UN GAS FLUORIZADO DE EFECTOS DE INVERNADERO, INCLUIDO EN EL PROTOCOLO DE KYOTO, CON UN POTENCIAL DE CALENTAMIENTO GLOBAL (GWP) = 1975.